

Voice of Logistics: Focus on Data Governance

Summary

As an essential asset of port, data plays an increasingly important role in the daily operation of port enterprises. Achieving effective integration of data from multiple subjects involved in port logistics (e.g. people, technology and process) is essential to deepen the construction of data and analytics (D&A) systems and improve the production efficiency of port enterprises.

For Session 1, aiming to realize a comprehensive assessment and optimization of the maturity of ICM's D&A system, this paper innovatively proposed to establish a standard D&A system **meta-network** model for port logistics as the basis for subsequent work. According to the expectations of ICM Corporation for the D&A system, this paper selected people, technology, process and data information as the modeling objects of the **meta-network**. Specific modeling elements and correlations were identified through government documents, institution reports, and academic publications. Finally, a standard D&A system **meta-network** model of port logistics with 33 nodes and 199 links was developed.

For Session 2, to select comprehensive D&A system maturity assessment indicators, a standard D&A system **meta-network analysis (MNA)** was conducted in this paper. From the perspective of effective integration of people, technology, process and data information of port logistics system, this paper selected 12 D&A system maturity evaluation indicators such as Process Data Information Needs Congruence and Data Information Based Task Completion. Subsequently, this paper used the indicator data obtained from **Monte Carlo stochastic simulation** as the input data of **PCA** to develop a quantitative assessment model for the D&A system maturity. We selected Mediterranean Shipping Company S.A as an application to demonstrate using **MNA-PCA** for D&A system maturity assessment. According to the analysis results, the score of illustrative enterprise's D&A system maturity was 85.14, and it was found that the enterprise should strengthen the construction of customs release information and in-port consolidation and distribution information.

For Session 3, this paper proposed to simulate the performance of the enterprise port logistics D&A system by developing a **stochastic Petri net (SPN)** model that is isomorphic to the **meta-network**. The average delay time of in-port transportation equipment of the illustrative enterprise was simulated using the **SPN** model and optimized based on the standard D&A system **meta-network**. According to the simulation results, the average detention time of transportation equipment was reduced from 140.17 minutes to 85.98 minutes, with a 38.7% reduction.

For Session 4, based on the model's effectiveness, we provided ICM companies with recommendations for applying the model developed in this paper. This paper detailed the critical steps needed to apply the model to other industries.

Keywords: Data and analytics (D&A) system; Meta-network; PCA; Stochastic Petri net (SPN); Monte Carlo simulation

Contents

1 Introduction	3
1.1 Problem Background	3
1.2 Our Work.....	3
2 Preparation of the Models	5
2.1 Assumptions	5
2.2 Notations	5
3 Model 1: Port Logistics D&A System Meta-Network Model	5
3.1 Meta-Network Model.....	5
3.2 Identification of Port Logistics Elements	6
3.3 The Establishment of Port Logistics D&A System Meta-Network Model.....	7
4 Model 2: MNA-PCA Based D&A System Maturity Assessment.....	8
4.1 Maturity Assessment Indicators for D&A System Based on MNA.....	9
4.2 Principal Component Analysis.....	11
4.3 Development of D&A System Maturity Assessment System.....	11
4.4 D&A System Maturity Assessment Application Demonstration and Recommendations	13
5 Model 3: Stochastic Petri Net for the Port Logistics Optimization Isomorphic with D&A System Meta-Network	14
5.1 Basic Theory of Stochastic Petri Nets (SPN).....	14
5.2 Stochastic Petri Net Modelling for the Port Logistics Optimization	15
5.3 Port Logistics Optimization for the Illustrative Enterprise.....	18
6 Sensitivity Analysis.....	20
6.1 Sensitivity Analysis of the Standard Port Logistics D&A System Maturity	20
6.2 Sensitivity Analysis of the Illustrative Enterprise Port Logistics SPN	20
7 Application Recommendations for ICM Corporation’s D&A System and Model Extensions	21
7.1 D&A System Application Recommendations.....	21
7.2 Model’s Industry Extensions.....	21
8 Model Evaluation	22
8.1 Strengths	22
8.2 Weaknesses	23

1 Introduction

1.1 Problem Background

As an important asset owned by the enterprise, data governance refers to its correctness and timeliness, control of data flow, permissions and management of security. The correct application of the data and analytics (D&A) system should be based on accurate and reasonable data. Port logistics service is a complex system engineering. The organization of port logistics services involves government regulatory agencies, port enterprises and various types of logistics service providers and customers in multiple departments and units. Its business side involves port inspection, logistics and transportation, customs clearance and review, and many other aspects. Establishing the data and analytics D&A system can help improve its overall operational efficiency and service quality.

The specific requirements of this question are as follows:

- Develop a D&A system maturity assessment indicator system and apply it to the illustrative enterprise's D&A system assessment.
- Demonstrate how to use the developed model to maximize the value of enterprise data assets.
- Apply the model to evaluate and optimize ICM's D&A system.
- Expand the application of the developed model to other companies or industries.

1.2 Our Work

Since this question did not give any port operation data for ICM Corporation, a quantitative model that can effectively integrate multiple types of essential information, the meta-network model, was developed as a basis for subsequent maturity assessment and process optimization. According to ICM Corporation's target requirements for the D&A system, we selected people, technology, process and data information as the modeling elements of the meta-network. Through literature analysis, we classified the types of people, technology, process and relevant data information involved in port logistics services and analyzed the correlations between the elements. We integrated port logistics services' components and associated relationships into a network to establish a standard D&A system meta-network model.

To comprehensively assess the maturity of the D&A system, we need to analyze the multi-level network indicators to select maturity indicators based on the established D&A system meta-network model. This paper selected 12 indicators such as Data Information Based Process Completion (DIBPC), Data Information Negotiation (DIN), and Process Data Information Needs Congruence (PDINC) as the critical indicators to measure the performance of people, technologies and processes in the D&A system. Due to the lack of data on the operation of the business, this paper used Monte Carlo simulations to capture the changes in the D&A system maturity assessment indicators under different scenarios. Principal component analysis was used to reduce the dimensionality of the indicator data in the Monte Carlo simulation and establish a maturity assessment model based on the D&A system meta-network. We applied the maturity model to Mediterranean Shipping Company S.A as an application demonstration of the model for ICM Corporation.

For ICM Corporation to maximize the benefit of its data information and reduce the transit time, this paper developed a Stochastic Petri Net (SPN) isomorphic to the D&A system meta-network. The SPN model is established by corresponding the elements of port logistics in the SPN to the elements in the D&A system meta-network and inheriting the correlation relationships between the elements in the meta-network. This paper selected the illustrative enterprise for the D&A system maturity assessment as the object of SPN logistics process optimization. This paper used the SPN model to simulate delays in the port logistics system of the illustrative enterprise and optimized the system based on the standard D&A system meta-network.

Finally, based on the model’s effectiveness, we recommended the established D&A system maturity assessment and optimization models to ICM. This paper detailed how the models can be extended to other enterprises or industries. A letter related to the maturity of ICM Corporation’s port logistics services D&A system is also provided to ICM Corporation’s customers to increase their confidence in the data practices.

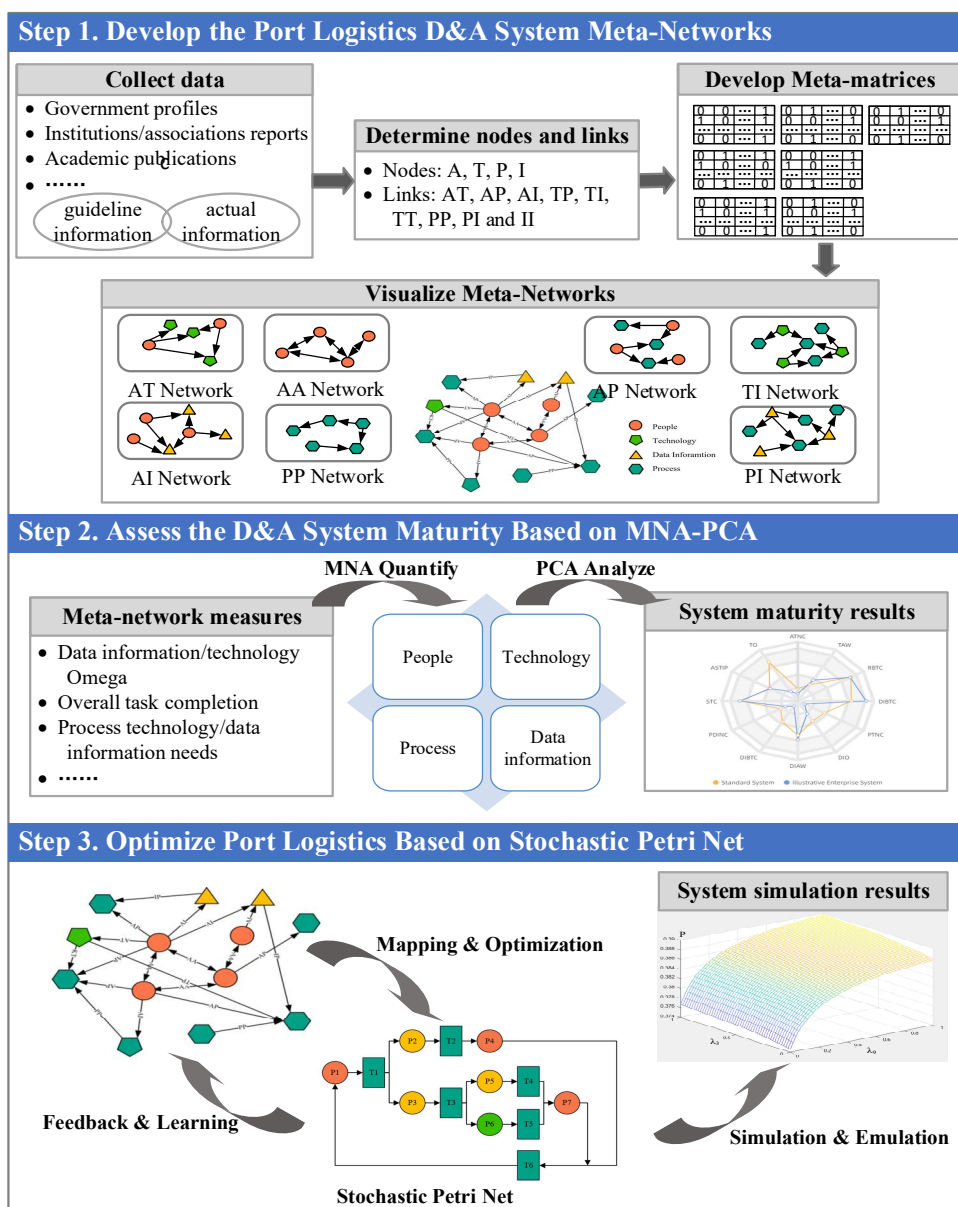

Fig. 1 Technology roadmap for this paper

2 Preparation of the Models

2.1 Assumptions

1. ICM Corporation's port-related business is not likely to change significantly shortly.
2. The maturity of the D&A system is only influenced by the people, technology, process and data information in the introduction to the problem.
3. The illustrative enterprise is consistent with the nature of ICM Corporation and is a good representation of the operations of ICM Corporation.
4. There is no conflict between the needs of the different departments in the ICM Corporation management team.

2.2 Notations

The key mathematical notations used in this paper are listed in **Table 1**.

Table 1 Notations used in this paper

Symbol	Description
f_e	The e th principal component score
β_e	The weight of the i th principal component
DIBTC	Data Information Based Task Completion
DIO	Data Information Omega
PTNC	Process Technology Needs Congruence
TO	Technology Omega
\bar{N}	The average token of the places
N	The average system delay time

3 Model 1: Port Logistics D&A System Meta-Network Model

The primary purpose of this section is to establish a port logistics D&A system meta-network to realize the integration of data information, people, technology and process and provide a basis for subsequent D&A system maturity assessment and optimization.

3.1 Meta-Network Model

Carley et al. (2007) proposed the concept of meta-network, which is a multi-level social network that includes multiple organizational elements (Carley *et al.*, 2007). Meta-network has a 'tree-like' hierarchical structure and can be seen as mapping multiple homogeneous or heterogeneous sub-network. By analyzing the meta-network model as a whole or more sub-networks within the meta-network, critical information about the structural characteristics of the system can be obtained.

Pestov (2009) argued that any natural system, such as society or organization, can be represented by a meta-network (Pestov, 2009). Various entities or elements in a system, including people, data information and resources, can be captured as meta-network nodes, as shown in **Fig. 2**. The port logistics services are characterized by large scale, multiple associations and

uncertainty. Therefore, the port logistics system is complex, with a hierarchy composed of multiple subjects. Based on the characteristics of ICM Corporation’s port logistics system and the objectives of ICM’s D&A system, we can learn that the meta-network model is well suited to this problem. The main steps in developing a meta-network model are identifying nodes and links.

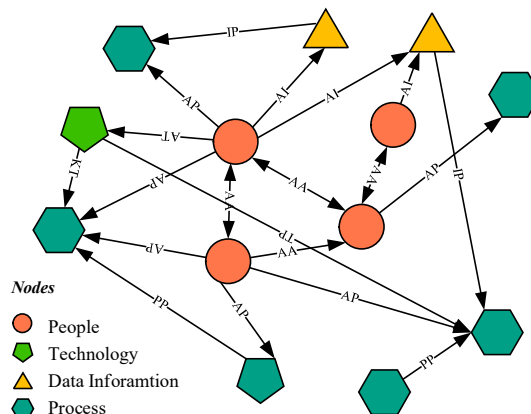

Fig. 2 Basic meta-network concept diagram

3.2 Identification of Port Logistics Elements

During the port logistics D&A system analysis, there is a non-negligible correlation between many factors such as people, technology, process, and data information. This paper needs to decompose the processes at the system level, analyze the various factors included, and consider the correlations.

Based on relevant technical specifications, government documents and related literature, this paper identifies a total of 33 critical elements based on the core of the port logistics transportation process (Almotairi and Lumsden, 2009). The identification results of port logistics elements are shown in **Table 2**.

Table 2 Identification of port logistics elements

Category	ID	ID Meaning
Process	P1	Vessel arrival
	P2	Vessels waiting for berth allocation
	P3	Vessel approaching the port
	P4	Container liner
	P5	Bill review
	P6	Loading and unloading operations
	P7	Assembled goods
	P8	Stockpile storage
	P9	Intra-port consolidation vehicle transportation
	P10	Customs supervision and release
	P11	Registration information ship leaving the post
Data Information	I1	Regulatory release information
	I2	Container liner information
	I3	Loading and unloading machinery information

	I4	Stockyard information
	I5	Intra-port information
	I6	Railroad port station information
	I7	Vessel information
Technology	T1	Technology for loading and unloading operations
	T2	Berth operation technology
	T3	Container box source organization technology
	T4	Stacking and mechanical loading and unloading synergistic technology
	T5	Cooperative technology of collecting and transporting machinery and loading and unloading machinery
	T6	Cooperative technology of berth operation and loading/unloading operation
	T7	Modern information technology
People	A1	Customs inspector
	A2	Port commanders
	A3	Valets
	A4	Longshoreman
	A5	Freight forwarder
	A6	Loading and unloading machinery operators
	A7	Accountant
	A8	Shipper

3.3 The Establishment of Port Logistics D&A System Meta-Network Model

Based on the identified port logistics elements, four-element types (i.e. Process (P), Data Information (I), People (A) and Technology (T)) are identified as meta-network four-dimensional nodes. In order to develop the port logistics D&A system and sort out the correlations between the elements of entities in port logistics, which are transformed into links between nodes, the standard port logistics D&A system meta-network is developed, as shown in Fig. 3. The port logistics D&A system meta-network will be explained in detail below.

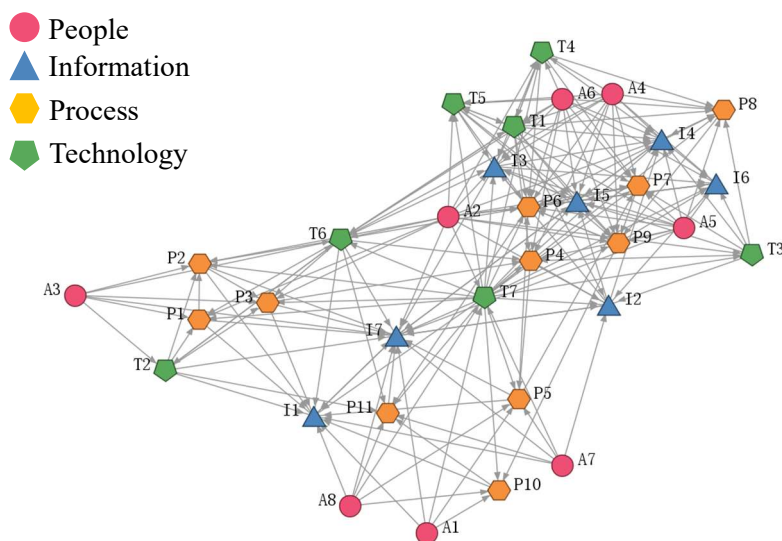

Fig. 3 The standard port logistics D&A system meta-network model

In the port logistics D&A system meta-network model, there are unidirectional or bidirectional associations between different nodes, and the following types of association networks are developed according to different associations in this paper, as shown in **Table 3**. For example, AP Net refers to the involvement of certain people needed to complete a specific process. TP Net refers to the skills required to complete a specific process. AI Net refers to the data information that someone has. The structural characteristics of a port logistics system can be described by analyzing the entire meta matrix or one or more networks in the matrix. The associated sub-network based on the node relationship matrix is shown in **Fig. 4**. By analyzing the meta-network, we can obtain practically meaningful multidimensional network indicators, which will be specified in *4.2 Maturity Assessment Indicators for D&A System Based on MNA*.

Table 3 Port logistics D&A system meta matrix

	People	Technology	Process	Data Information
People	--	AT Net	AP Net	AI Net
Technology	--	TT Net	TP Net	TI Net
Process	--	--	PP Net	PI Net
Data Information	--	--	--	II Net

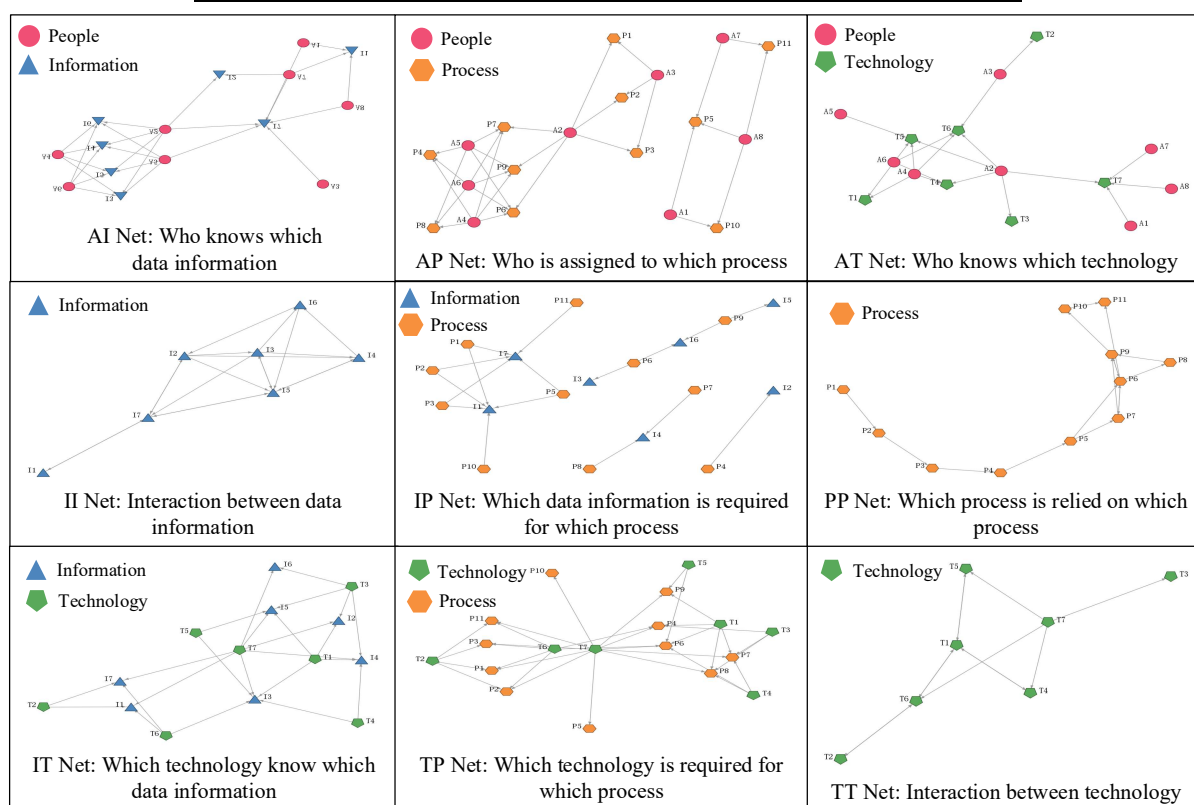

Fig. 4 Port logistics D&A system meta-network sub-network system diagram

4 Model 2: MNA-PCA Based D&A System Maturity Assessment

In this section, the meta-network analysis (MNA) was carried out based on ICM’s D&A system targets, and indicators were selected that enable a comprehensive assessment of the D&A system maturity. This paper calculated the indicator dataset through Monte Carlo simulation and performed principal component analysis (PCA) to determine the indicator weights.

Finally, the model was applied to company Mediterranean Shipping Company S.A as an application demonstration.

4.1 Maturity Assessment Indicators for D&A System Based on MNA

The target of developing a D&A system is to maximize the use of data assets by enhancing the correlation between people, technology and process to form collaborative management of the whole life cycle. The key to the selection of indicators is to describe the collaborative process of people, technology and data information during the completion of logistics operations to achieve a comprehensive assessment of the maturity of the D&A system. Therefore, this paper selects a multi-layered network assessment indicator with a core of the process, as shown below. All computed elements in the following are the meta-network 0-1 relationship matrix as represented in **Table 3** and are calculated as matrix operations.

- Agent Data Information Needs Congruence (ADINC): This indicator represents the amount of data information that is missing for the agent to complete its assigned process. Let $NDI = AP * IP'$ = data information needed by agents to do their assigned process. The formula for the ADINC for agent i is shown in **Equation (1)**.

$$ADINC_i = \frac{\text{sum}(NDI(i, :)) .* \sim AI(i, :)}{\text{sum}(NDI(i, :))} \quad (1)$$

- Agent Technology Needs Congruence (ATNC): This indicator represents the amount of technology missing for the agent to complete its assigned process. Let $NT = AP * TP'$ = technology agents need to do their assigned process. The formula is familiar with that of ADINC.
- Process Data Information Needs Congruence (PDINC): The number of data information not supplied to a process, but required to do the process, is expressed as a fraction of the total knowledge required for the task. It is similar to Agent Data Information Needs Congruence but quantifies only the undersupply of data information to tasks, as shown in **Equation (2)**.

$$PDINC_i = \frac{\text{sum}(IP'(i, :)) .* \sim (AP' * AI(i, :))}{\text{sum}(IP'(i, :))} \quad (2)$$

- Process Technology Needs Congruence (PTNC): This is Process Data Information Needs Congruence with the data information-based networks replaced with the corresponding technology-based networks.
- Data Information Actual Workload (DIAW): The data information an agent uses to perform the processes to which it is assigned. DIAW for agent i is computed as **Equation (3)**:

$$DIAW_i = \frac{[AI * IP * AP'](i, i)}{\text{sum}(IP)} \quad (3)$$

- Technology Actual Workload (TAW): The technology an agent uses to perform the processes to which it is assigned. The formula can be found in DIAW.
- Data Information Based Task Completion (DIBTC): The fraction of the assigned processes that can be completed by agents based on data information. DIBTC for agent i is computed as **Equation (4)**:

$$DIBTC_i = \frac{|T| - |(IP' - AP' * AI)|}{|T|} \tag{4}$$

- Technology Based Task Completion (TBTC): This is Data Information Based Task Completion with the data information-based networks replaced with the corresponding technology-based networks.
- Social Technical Congruence (STC): The proportion of the overall needs of a process that are met by the coordination of people working through a process. STC for agent *i* is computed as **Equation (5)**:

$$STC_i = \frac{sum[I((AP * PP * AP') .* AA > 0)]}{sum(I((AP * PP * AP') > 0))} \tag{5}$$

where, $I(A > 0)$ denotes a function that if true returns a value of 1.

- Agent Socio Technology-Information Power (ASTIP): A measure of actor power based on access to data information, technology, and process. ASTIP is the Out-Degree Centrality of the binarized concatenated network: [AT AI AP]
- Data Information Omega (DIO): The degree to which agents reuse data information while doing their processes. DIO for agent *i* is computed as **Equation (6)**:

$$DIO_i = \frac{sum[((T' .* AT' * AT) .* KT') .* KT']}{sum(KT')} \tag{6}$$

- Technology Omega (TO): The degree to which agents reuse technology while doing their processes. This is Data Information Omega with the data information-based networks replaced with the corresponding technology-based networks.

The indicators selected above address the concerns of ICM Corporation’s management team, as shown in **Table 5**. The results of the standard D&A system maturity assessment metrics are shown in **Table 6**.

Table 5 Indicators and concerns solved table

Indicators	Solved concerns
Agent Data Information Needs Congruence	Cataloging of data assets; Integration of people, technology, processes and data information; Data governance.
Process Data Information Needs Congruence	
Data Information Actual Workload	
Data Information Based Task Completion	
Data Information Omega	
Agent Technology Needs Congruence	Skills of recruited staff; Staff training; Technical solution reliability measurement.
Process Technology Needs Congruence	
Technology Actual Workload	
Technology Based Task Completion	
Technology Omega	
Agent Socio Technology-Information Power	Determination of talent reserve deficiencies; Determination of the number of employees; Selection of talents in demand.
Social Technical Congruence	

Table 6 Calculation of standard D&A system maturity indicators

Indicators	Value	Indicators	Value	Indicators	Value	Indicators	Value
ATNC	0.188	DIBTC	0.636	DIAW	0.522	STC	0.675

TAW	0.287	PTNC	0.364	DIBTC	0.364	ASTIP	0.385
TBTC	0.727	DIO	0.353	PDINC	0.235	TO	0.682

4.2 Principal Component Analysis

Principal Component Analysis (PCA) is a multivariate statistical method (Wold *et al.*, 1987). PCA converts a set of correlated variables into a set of orthogonal, uncorrelated variables using an orthogonal transformation called a principal component. The modeling steps for PCA are shown in following steps.

Step 1: Calculate the component score.

$$\delta_i = \sum_{e=1}^n \beta_e f_e \quad (7)$$

where f_e denotes the e th principal component score and the weight of the i th principal component is denoted by β_e .

Step 2: Calculate the information contribution and cumulative contribution of each component eigenvalue.

$$b_i = \frac{\lambda_i}{\sum_{\theta=1}^i \lambda_{\theta}}, \quad i = 1, 2, \dots, 9 \quad (8)$$

$$\alpha_e = \frac{\sum_{e=1}^p \lambda_e}{\sum_{\theta=1}^9 \lambda_{\theta}} \quad (9)$$

where b_i is the contribution of each component X_i is the information contribution and α_e is the cumulative contribution of each component.

Step 3: Calculate the overall score.

$$\delta_i = \sum_{e=1}^n \beta_e b_e \quad (10)$$

where b_e is the information contribution of the e th principal component, and a comprehensive evaluation can be made based on the combined score.

4.3 Development of D&A System Maturity Assessment System

We performed 50 Monte Carlo simulations to randomly remove elements from a standard port logistics D&A system meta-network model. Data from 50 D&A system maturity assessment simulations were recorded and used as the input data set for the PCA. Due to space limitations, only some of the Monte Carlo simulation data is shown in **Table 6**.

Indicators/Simulation times	1	2	3	4	5	...	48	49	50
ATNC	0.205	0.22	0.205	0.225	0.243	...	0.2	0.225	0.196
TAW	0.273	0.267	0.273	0.258	0.292	...	0.281	0.258	0.289
TBTC	0.727	0.182	0.455	0.727	0.727	...	0.7	0.576	0.8
...
ASTIP	0.411	0.343	0.406	0.366	0.377	...	0.385	0.38	0.391

The PCA was performed on the maturity assessment system using MATLAB. According to the calculated results, the cumulative variance contribution of the first six principal components reached 85%, and their characteristic roots were $\lambda_1 = 3.84$, $\lambda_2 = 2.30$, $\lambda_3 = 1.65$, $\lambda_4 = 1.32$, and $\lambda_5 = 1.14$. Therefore, the first 5 principal components were selected as indicators

in this paper. The PCA calculated fragmentation diagram is shown in **Fig. 5**.

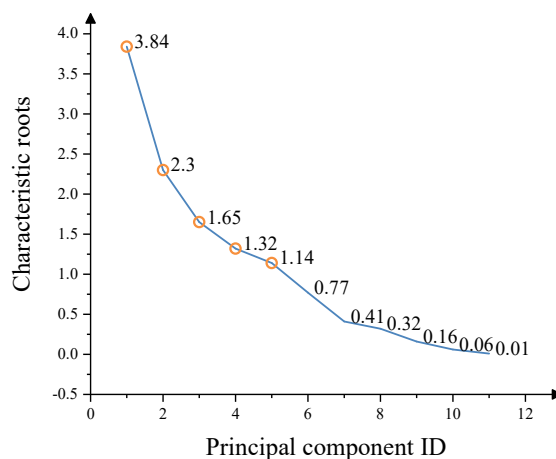

Fig. 5 PCA fragmentation diagram

The results of the linear combination coefficients and weights of the PCA principal components are shown in **Table 7**.

Table 7 Linear combination coefficients and weighting results

	Component 1	Component 2	Component 3	Component 4	Component 5	
Feature Root	3.84	2.301	1.654	1.319	1.141	Weight
Variance Extraction	32.00%	19.17%	13.78%	10.99%	9.51%	
ATNC	0.36	0.24	0.24	0.29	0.27	10.3%
TAW	0.17	0.55	0.12	0.20	0.06	8.28%
RBTC	0.01	0.30	0.65	0.13	0.19	7.58%
DIBTC	0.41	0.30	0.12	0.17	0.12	9.62%
PTNC	0.49	0.01	0.07	0.05	0.14	7.66%
DIO	0.21	0.48	0.17	0.31	0.06	9.13%
...

The expression for the overall D&A system maturity score is shown in **Equation (11)**. Its weight distribution tree diagram is shown in **Fig. 6**.

$$\begin{aligned}
 F = & 0.1037ATNC + 0.0962DIBTC + 0.0920STC + 0.0913DIO + 0.0912TO \\
 & + 0.0909DIAW + 0.8028TAW + 0.0766PTNC + 0.0758RBTC \\
 & + 0.0709DIBTC + 0.0701PDINC + 0.0583ASTIP
 \end{aligned}
 \tag{11}$$

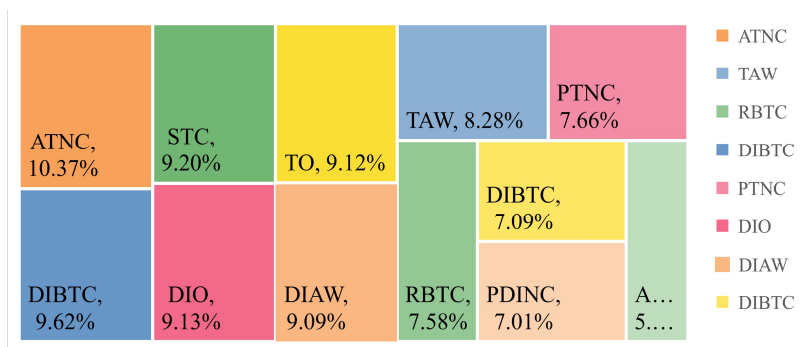

Fig. 5 D&A system maturity assessment indicator weighting tree diagram

4.4 D&A System Maturity Assessment Application Demonstration and Recommendations

Mediterranean Shipping Company S.A is a global company engaged in shipping and logistics, established in 1970, with more than 200 routes deployed in more than 150 countries and territories worldwide, and the second-largest shipping capacity in the world. Our search of the relevant literature and the analysis of the company's financial reports revealed that Mediterranean Shipping Company S.A has specific problems in terms of information technology and the working capacity of the port command staff (S. *et al.*, 2015).

The company’s Regulatory Release Information (I1) and Intra-port information (I5) were not updated on time, resulting in prolonged in-port detention of vessels. In addition, the stacking and mechanical loading and unloading synergistic technology (T4) and modern information technology (T7) were relatively backward. Port commanders (A2) sometimes failed at vessels waiting for berth allocation (P2) and customs supervision and release (P10) due to missing real-time data information. Due to lack of authority, longshoreman (A4) cannot obtain stockyard information (I4), resulting in failure to arrive on duty in time. We fed back the deficiencies of the illustrative enterprise to the meta-network model of the standard port logistics D&A system. The specific changes of the meta-network are summarized in **Table 8**.

Table 8 Summary of changes to the meta-network structure

Missing type	Element ID
Missing nodes	I1, I5, T4, T7
Missing links	A2-P2, A2-P10, A4-I4

We input the above changes into the standard port logistics D&A system meta-network and calculated maturity indicators for the D&A system of the illustrative enterprise. The ratio of the maturity score of the illustrative enterprise to the maturity score of the standard system is used as the final score, which is calculated as **0.8514**. The results of calculating the maturity indicators for the illustrative enterprise and the standard system are shown in **Fig. 6**.

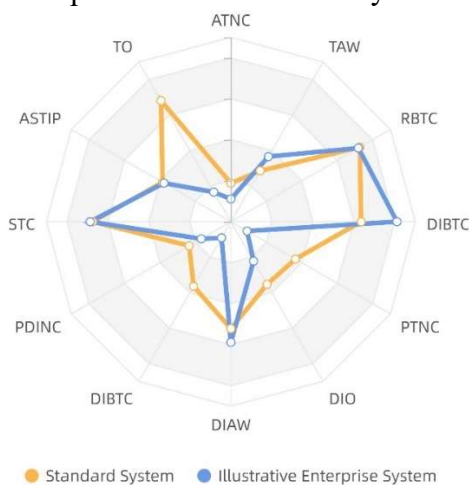

Fig. 6 Radar chart comparing the standard system with the illustrative enterprise system indicators

Based on the calculation results, we can see that the illustrative enterprise’s DIBTC, DIO,

PTNC and TO indicators are significantly smaller than the standard system. We were able to calculate through the D&A system meta-network model matrix the links that need to be enhanced by data information for this business, as summarized in **Table 9**. Based on the result, the enterprise can strengthen these segments in a targeted manner.

Table 9 Illustrative enterprise D&A system optimization recommendations

Links or nodes to be filled or strengthened	Element ID
Links	A2-P2, A2-P10, A2-I2, A2-I5, A2-I7, A3-P3, A4-I4, A7-T7
Nodes	I1, I5, T4, T7, A2, A7

5 Model 3: Stochastic Petri Net for the Port Logistics Optimization Isomorphic with D&A System Meta-Network

This section describes how to develop a stochastic Petri net model of port logistics using the illustrative enterprise's D&A system meta-network and simulate the average detention time of the illustrative enterprise's port transport equipment. The illustrative enterprise D&A system is then optimized based on the standard D&A system meta-network model.

5.1 Basic Theory of Stochastic Petri Nets (SPN)

Petri nets are modelling tools that describe models using specific notations and are often used for process modelling (Lee and Mitici, 2020). It features a graphical, digital modelling tool for various systems, especially discrete-event dynamic systems. It provides a powerful tool for describing and studying information processing systems that are parallel, asynchronous and stochastic.

With the stochastic Petri net (SPN) model, the system's performance can be quantified through a series of transformations to obtain the busy probability, the idle probability, the variable utilization, etc., of the repository. In this case, the busy probability of the place reflects the utilization of resources and the active status of the tasks in the actual system. The utilization of the transition reflects information such as system throughput and latency.

We define a SPN as a seven-tuple, $\Sigma = (P, T, F, K, W, M_0, \lambda)$.

- Place (P ○) indicates the location and state of the system, and each circle can hold a certain amount of resources.
- Transition (T ■) refers to the consumption, use and generation of resources in the system.
- Token (\bullet) can be moved between two places, the number of which represents the number of resources in the place.
- F is the set of directed arcs.
- W is the weight function of a directed arc, the set of nodal flow relationships.
- K is a function of the capacity of the library.
- M_0 is the initial marker.
- λ is the set of average implementation rates of the transition. λ_i is the average implementation rate of the transition, and denotes the number of implementations per

unit of time.

Analyzing the performance of a system based on SPN is described in detail as shown in the following steps.

Step 1: Develop a process SPN model by associating a realistic delay to all the transitions based on the model already built.

Step 2: Develop a reachable tree based on the known SPN model. According to the distribution of tokens (resources) in the model repository and the triggering rules of transitions, a Markov chain is obtained isomorphically.

Step 3: Based on Markov chains, the transfer rate matrix for Markov processes are developed, and the steady-state probabilities are obtained by solving the matrix equations.

Step 4: Calculate the final performance metrics to determine the final performance estimate required for the entire system described by the model.

5.2 Stochastic Petri Net Modelling for the Port Logistics Optimization

Before modelling, it is necessary to analyze the specific processes that port logistics needs to go through and then map the critical elements of these processes to the process elements in the SPN. The system initializes the location of the resource, which is reflected in the SPN model as the initial identification, and in the case of port logistics transport processes, the resource can be a container or a transport truck. The state and condition of the resource, the corresponding element in the SPN model, is the library. Place corresponds to people, technology and data information in the developed standard D&A system meta-network. Transitions represent the state of use or progress, corresponding to the process element in the standard D&A system meta-network. The logical relationships between place and transition in the SPN use the same logical links as the meta-network links. Corresponding the elements of the D&A system meta-network to the essential elements of the SPN is the basis for subsequent work. The workload of Petri net modelling is significantly reduced by developing an SPN that is isomorphic to the D&A system meta-network, improving the efficiency of the study.

Based on the detailed analysis and description of the illustrative enterprise’s port logistics D&A system meta-network, the processes are modelled with the basic Petri net modelling methods and principles. The illustrative enterprise’s SPN model of the port logistics D&A system is shown in Fig. 7. The colors in the diagram remain the same as the colors of the node types in the meta-network. The specific meanings of place and transition in the illustrative enterprise’s SPN are shown in Table 10.

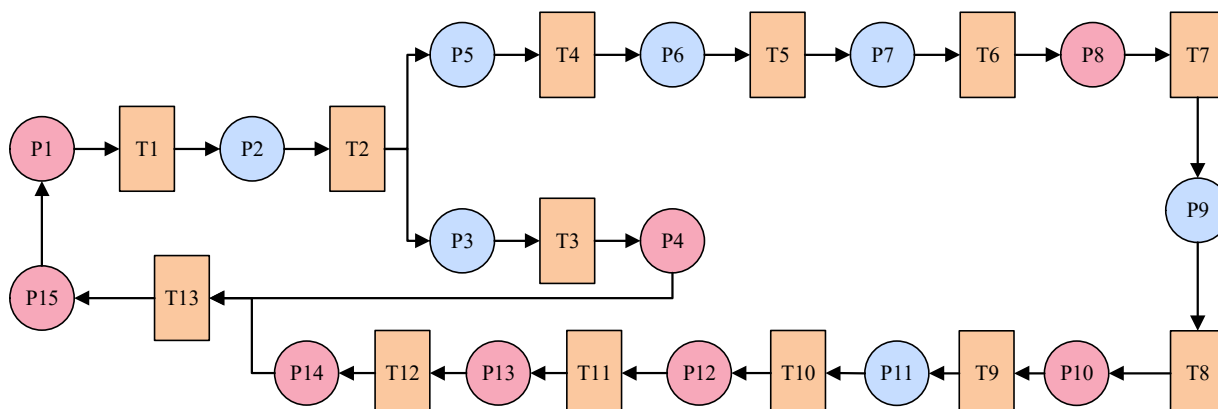

Fig. 7 Illustrative enterprise's port logistics operation process SPN
Table 10 Implications of the port logistics SPN place and transition

Place	Meaning	Transi- tion	Meaning
P1	Shipper (A8)	T1	Ship arriving in port (P1)
P2	Vessel information (I7)	T2	Vessel waiting for berth allocation (P2)
P3	Regulatory release information (I1)	T3	Vessel approaching port (P3)
P4	Container liner information (I2)	T4	Container liner (P4)
P5	Accountant (A7)	T5	Bill review (P5)
P6	Loading and unloading machinery information (I3)	T6	Loading and unloading operations (P6)
P7	Stockyard information (I4)	T7	Loading and unloading operations (P6)
P8	Longshoreman (A4)	T8	Stockpile storage (P7)
P9	Intra-port information (I5)	T9	Intra-port consolidation vehicle transport (P9)
P10	Longshoreman (A4)	T10	Intra-port consolidation vehicle transport (P9)
P11	Regulatory release information (I1)	T11	Bill review (P5)
P12	Accountant (A7)	T12	Customs supervision (P10)
P13	Customs inspector (A1)	T13	Vessels leaving port (P11)
P14	Valets (A3)		
P15	Consignee		

First, this paper needs to validate the validity of the already established SPN model of the illustrative enterprise. Based on the already established SPN model of the illustrative enterprise port logistics D&A system, the correlation matrix A is calculated as **Equation (12)**.

$$A = \begin{pmatrix} -1 & 1 & 0 & 0 & 0 & 0 & 0 & 0 & 0 & 0 & 0 & 0 \\ 0 & -1 & 1 & 0 & 0 & 0 & 0 & 0 & 0 & 0 & 0 & 0 \\ 0 & 0 & -1 & 1 & 0 & 1 & 0 & 0 & 0 & 0 & 0 & 0 \\ 0 & 0 & 0 & -1 & 1 & 0 & 0 & 0 & 0 & 0 & 0 & 0 \\ 0 & 0 & 0 & 0 & 0 & -1 & 1 & 0 & 0 & 0 & 0 & 0 \\ 0 & 0 & 0 & 0 & 0 & 0 & -1 & 1 & 0 & 0 & 0 & 0 \\ 0 & 0 & 0 & 0 & 0 & 0 & 0 & -1 & 1 & 0 & 0 & 0 \\ 0 & 0 & 0 & 0 & 0 & 0 & 0 & 0 & -1 & 1 & 0 & 0 \\ 0 & 0 & 0 & 0 & 0 & 0 & 0 & 0 & 0 & -1 & 1 & 0 \\ 0 & 0 & 0 & 0 & 0 & 0 & 0 & 0 & 0 & 0 & -1 & 1 \end{pmatrix} \quad (12)$$

Solve for $AX = 0$ to obtain a set of invariant bits.

$$X_1 = (1,1,1,1,0,1,0,0,0,0,1,1)^T \quad (13)$$

$$X_2 = (1,1,1,0,1,0,1,1,1,1,1,1)^T \quad (14)$$

The following conclusions can be drawn from the correlation matrix A and the invariant X (Chahrour *et al.*, 2021).

(1) All depots in the constructed model have input conditions, i.e., adjacent input variants and alternate depots and variants, indicating a very smooth articulation process of the port operation process.

(2) There are no processes in the constructed model that can never be performed. The model has neither isolated elements (places and transitions) nor connections between places or between transitions, which suggests that every process in the port operation can be executed.

The average delay and rate consumed by each transition in the SPN model of the illustrative enterprise is shown in **Table 11**.

Table 11 Illustrative enterprise SPN average transition delay and rate

Transition	Delay	Rate λ	Transition	Delay	Rate λ
T_1	20	0.05	T_7	10	0.1
T_2	15	0.00667	T_8	20	0.05
T_3	30	0.0333	T_9	10	0.1
T_4	10	0.1	T_{10}	3	0.333
T_5	5	0.2	T_{11}	1	1
T_6	3	0.333			

The equation for the probabilistic relationship between the states of the system is calculated, as in **Equation (15)**.

$$\left\{ \begin{array}{l}
 \lambda_1 x_0 = \lambda_{11} x_{13} \\
 \lambda_2 x_1 = \lambda_1 x_0 \\
 \lambda_3 x_2 = \lambda_2 x_1 \\
 (\lambda_4 + \lambda_5) x_3 = \lambda_3 x_2 \\
 (\lambda_4 + \lambda_6) x_4 = \lambda_5 x_3 \\
 (\lambda_4 + \lambda_7) x_5 = \lambda_6 x_4 \\
 \lambda_4 x_6 = \lambda_7 x_5 \\
 \lambda_5 x_7 = \lambda_4 x_3 \\
 \lambda_6 x_8 = \lambda_4 x_4 + \lambda_5 x_7 \\
 \lambda_7 x_9 = \lambda_4 x_5 + \lambda_6 x_8 \\
 \lambda_8 x_{10} = \lambda_4 x_6 + \lambda_7 x_9 \\
 \lambda_9 x_{11} = \lambda_8 x_{10} \\
 \lambda_{10} x_{12} = \lambda_9 x_{11} \\
 x_1 + x_2 + x_3 + x_4 + x_5 + x_6 + x_7 + x_8 + x_9 + x_{10} + x_{11} + x_{12} + x_{13} = 1
 \end{array} \right. \tag{15}$$

The table of probabilities for each state was obtained by programming in MATLAB as follows.

Table 12 Steady state probability values for each marker

Steady state markers	Probability	Steady state markers	Probability
$P(M_0)$	0.1672	$P(M_7)$	0.0139
$P(M_1)$	0.1254	$P(M_8)$	0.0122
$P(M_2)$	0.2511	$P(M_9)$	0.0622
$P(M_3)$	0.0279	$P(M_{10})$	0.1672
$P(M_4)$	0.0129	$P(M_{11})$	0.0836
$P(M_5)$	0.0214	$P(M_{12})$	0.0251
$P(M_6)$	0.0214	$P(M_{13})$	0.0084

According to the reachable tree of the reachable SPN model of the process, the token distribution in each representation state can be obtained.

Table 13 Identification status and inclusion of place and place busy probability

Maker	Place	Busy probability	Maker	Place	Busy probability
M_0	P_1	--	M_7	P_5/P_6	0.0251
M_1	P_2	0.1672	M_8	P_6/P_7	0.0836
M_2	P_3	0.1254	M_9	P_6/P_8	0.1886
M_3	P_4	0.2511	M_{10}	P_6/P_9	0.0836
M_4	P_4/P_7	0.0836	M_{11}	P_{10}	0.02511
M_5	$P_4/P_5/P_8$	0.0418	M_{12}	P_{11}	0.0084
M_6	P_4/P_9	0.255	M_{13}	P_{12}	--

The paper then calculated the system average token number of places, the average marker flow rate into the system and the average system delay time in the illustrative enterprise.

$$\bar{N} = \bar{\mu}_2 + \dots + \bar{\mu}_{10} = P[M(P_2) = 1] + \dots + P[M(P_{10}) = 1] = 1.1718 \tag{16}$$

$$\lambda = R(T_1, P_2) = U(T_1) \times \lambda_1 = 8.36 \times 10^{-3} \tag{17}$$

$$N = \frac{\bar{N}}{\lambda} = 140.167 \tag{18}$$

According to the calculation results, the average delay of the SPN of the example enterprise port logistics D&A system reaches 140.167 minutes. In the next section, we will optimize the example enterprise SPN to reduce the delay time of transport vehicles in ports.

5.3 Port Logistics Optimization for the Illustrative Enterprise

Based on the developed standard D&A system meta-network model, an optimized SPN model was developed. The main changes compared to the unoptimized illustrative enterprise model are:

- (1) The provision of vessel information to the customs department immediately upon arrival of the vessel is shown as T2 ahead of schedule, in parallel with T3.
- (2) Container unloading is carried out in parallel with ticket checking and is represented in the model as T4 and T5 in parallel.
- (3) The previous manual checking of box numbers has been replaced by an automatic check using the RFID container tagging system.

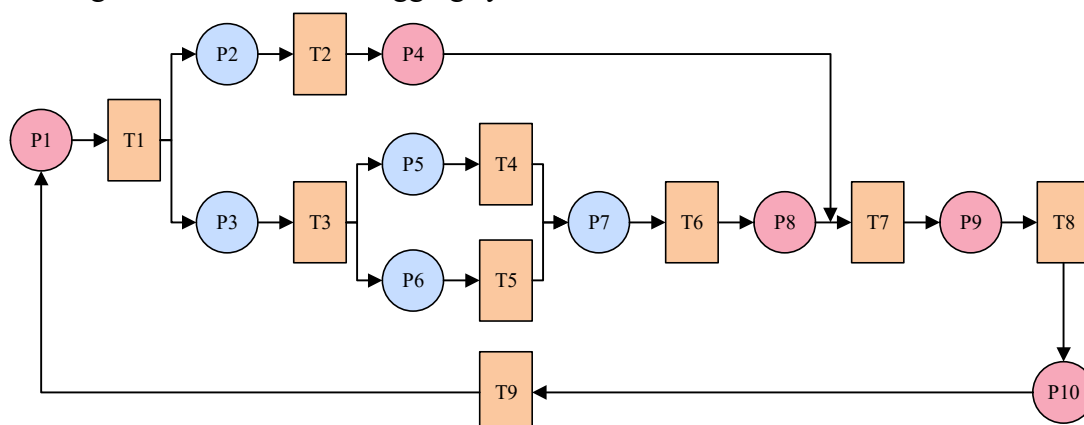

Fig. 8 Optimized illustrative enterprise SPN model

Table 14 Optimized implications of the port logistics SPN place and transition

Place	Meaning	Transi- tion	Meaning
-------	---------	-----------------	---------

P1	Shipper (A8)	T1	Ship arriving in port (P1)
P2	Vessel information (I7)	T2	Vessel waiting for berth allocation (P2)
P3	Regulatory release information (I1)	T3	Vessel approaching port (P3)
P4	Loading and unloading machinery information (I3)	T4	Container liner (P4)
P5	Stockyard information (I4)	T5	Loading and unloading operations (P6)
P6	Longshoreman (A4)	T6	Stockpile storage (P7)
P7	Intra-port information (I5)	T7	Intra-port consolidation vehicle transport (P9)
P8	Longshoreman (A4)	T8	Customs supervision (P10)
P9	Customs inspector (A1)	T9	Vessels leaving port (P11)
P10	Consignee		

The system average delay and rate of each transition in the SPN model after structural optimization based on the meta-network is shown in **Table 15**. Due to the strengthened management and organization of the operation, the working time of the container unloading operation has been shortened, so the delay of the corresponding transition T4 has been reduced from 30-time units to 20-time units.

Table 15 Optimized illustrative enterprise SPN average transition delay and rate

Transition	Delay	Rate λ	Transition	Delay	Rate λ
T_1	20	0.05	T_6	10	0.1
T_2	10	0.1	T_7	20	0.05
T_3	15	0.0667	T_8	10	0.1
T_4	20	0.05	T_9	1	1
T_5	5	0.2			

The same as the calculation process before optimizing the example enterprise SPN, the system average token number of the place, the average mark flow rate flowing into the system and the system average delay time were calculated.

$$\bar{N} = \bar{\mu}_2 + \dots + \bar{\mu}_{10} = P[M(P_2) = 1] + \dots + P[M(P_{10}) = 1] = 1.5829 \tag{19}$$

$$\lambda = R(T_1, P_2) = U(T_1) \times \lambda_1 = 1.841 \times 10^{-2} \tag{20}$$

$$N = \frac{\bar{N}}{\lambda} = 85.980 \tag{21}$$

After we optimized the SPN model of the illustrative enterprise based on the standard port logistics D&A system meta-network model, the average system delay was reduced by 38.7%, 54.187 minutes.

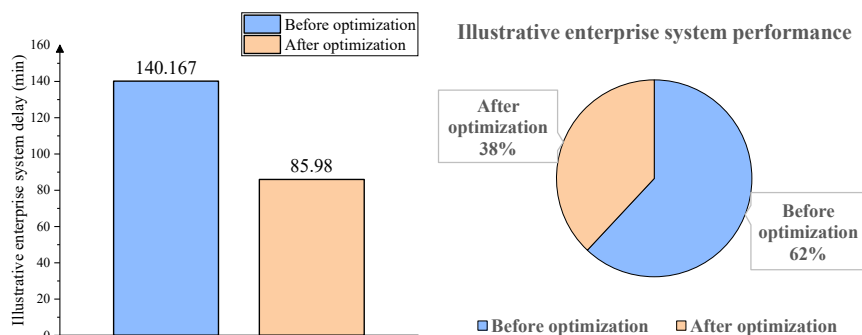

Fig. 9 Illustrative enterprise system performance comparison before and after optimization

6 Sensitivity Analysis

6.1 Sensitivity Analysis of the Standard Port Logistics D&A System Maturity

This paper introduces Monte Carlo stochastic simulations to validate the developed MNA-PCA based maturity assessment model for standard port logistics D&A systems. The Monte Carlo simulation contains a total of four scenarios, which are the random removal of one node, two nodes, three nodes and four nodes from the standard DA system meta-network. Fifty simulations were performed for each scenario, and the average of 12 D&A system maturity indicators was recorded. The average value of the indicators for each scenario was compared to the indicators for the standard meta-network, and a sensitivity analysis was performed, as shown in **Fig. 10**. As shown in **Fig. 10**, the overall change in the indicator for the scenario where four nodes are removed is significant, while the indicator remains relatively flat when one node is removed. Notably, the changes in the sensitivity of the indicators at the four deleted nodes are consistent with the changes in the indicators of the illustrative enterprise selected in this paper, demonstrating the stability and feasibility of the model developed in this paper.

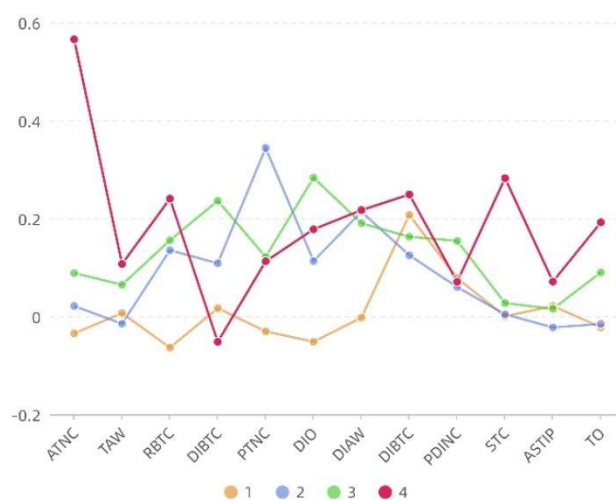

Fig. 10 Sensitivity analysis of indicators in different scenarios

6.2 Sensitivity Analysis of the Illustrative Enterprise Port Logistics SPN

This paper selected the most likely busy states M_3 and M_9 in **Table 13** for sensitivity simulations (Elusakin and Shafiee, 2020). We changed the λ_3 and λ_9 corresponding to the two states continuously in units of 0.01 from 0.01 to 1, thus calculating the change in the probability of stranding of the transport equipment, as shown in **Fig. 11**. We can fit this surface to quantitatively calculate the detention probability of transportation equipment and provide a basis for the decision-making of port enterprises.

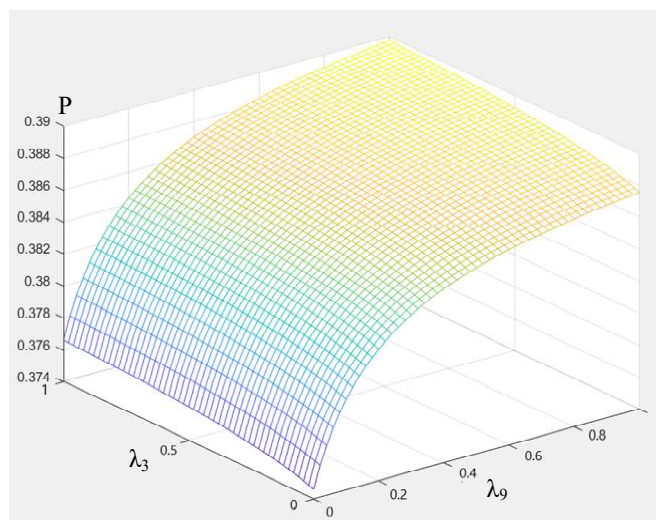

Fig. 11 Change surface of transportation equipment detention probability

7 Application Recommendations for ICM Corporation's D&A

System and Model Extensions

7.1 D&A System Application Recommendations

According to the maturity assessment results and the SPN port optimization results of the illustrative enterprise, we can see that the D&A system meta-network model established in this paper has good results.

The D&A system maturity assessment model based on MNA-PCA is easy to operate. According to the standard D&A system meta-network model, it is only necessary for an ICM company to delete the nodes or links that the company cannot realize. Then, the model will present the ICM company's port logistics system, calculate the ICM company's D&A system maturity score, and detect the problems existing in the system. The SPN model for port logistics is highly accurate and integrative and can simulate the average delay of ICM ports to the greatest extent possible.

The D&A system maturity indicators screened by the meta-network analysis method in this paper effectively address the relevant requirements of the ICM departments for D&A systems. In addition, the indicators selected relate to the interaction process between people, technology, processes and data information, which can better inform do not decisions for the ICM management team.

7.2 Model's Industry Extensions

The key to the cross-industry extension of the model developed in this paper is to analyze the differences in logistics operations across industries. The people, technology, process and data information involved in logistics processes are different in different industries. The cross-industry extension of the model first requires the construction of meta-network models of logistics D&A systems in different industries. The steps for specific model expansion are shown below in **Fig. 12**.

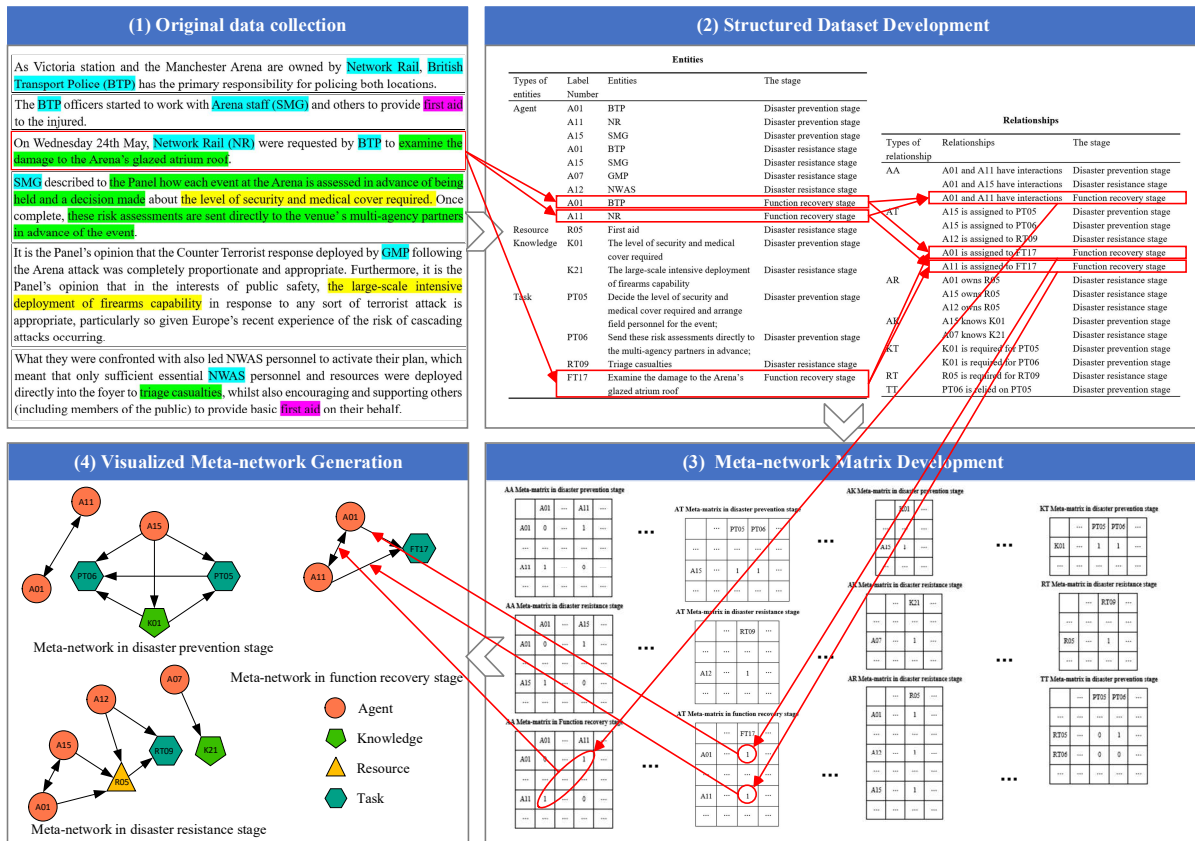

Fig. 12 Model expansion flow chart

Step 1: Gather critical information on the logistics processes of the target industry. Sources of information can be government documents, agency reports or academic publications, etc.

Step 2: Determine the nodes and links of the meta-network according to the enterprise's objectives of building the D&A system. The D&A system meta-network model nodes can be people, knowledge, resources, and processes.

Step 3: Identify the sub-networks and determine the correlation between sub-network nodes.

Step 4: Input critical nodes and correlations into the D&A system meta-network model to visualize the meta-network.

Step 5: Finally, a meta-network-based enterprise D&A system maturity assessment and enterprise logistics SPN model simulation is carried out.

The model developed in this paper is highly integrative, allowing additions, deletions and simulations to be made to the model at any time, and will reach a wide range of applications in different industries.

8 Model Evaluation

8.1 Strengths

1. This paper innovatively combines a meta-network model with a port logistics D&A

system. The meta-network model effectively combines people, skills, processes and data information in port logistics operations. Solves the difficulties of port logistics companies with multiple associations and subjects when it comes to data governance.

2. The D&A system maturity assessment system was established through the association of meta-network analysis and principal component analysis. The DA maturity assessment indicators, which are systematic and comprehensive, enable the indicators to be given practical meaning from a multi-component perspective.

3. An innovative proposal to build stochastic Petri nets isomorphic to meta-networks. This process greatly simplifies the complex process of traditional Petri net modelling. The developed SPN model can quantitatively assess the average delay of a company's port logistics system.

4. The meta-network model applied in this paper is highly extensible and provides new ideas and perspectives for port logistics data information governance.

8.2 Weaknesses

1. Only one representative enterprise has been selected to demonstrate the model proposed in this paper. Future research could add example systems.

2. The meta-network model of the port logistics D&A system established in this paper is based on the literature and relevant policy documents only and can be subject to expert consultation in the event of sufficient time.

References:

- Almotairi, B. & Lumsden, K. (2009), "Port logistics platform integration in supply chain management", *International Journal of Shipping and Transport Logistics*, Vol. 1 No. 2, pp. 194-210.
- Carley, K. M., Diesner, J., Reminga, J. & Tsvetovat, M. (2007), "Toward an interoperable dynamic network analysis toolkit", *Decision Support Systems*, Vol. 43 No. 4, pp. 1324-1347.
- Chahrour, N., Nasr, M., Tacnet, J. & Bérenguer, C. (2021), "Deterioration modeling and maintenance assessment using physics-informed stochastic Petri nets: Application to torrent protection structures", *Reliability Engineering & System Safety*, Vol. 210107524.
- Elusakin, T. & Shafiee, M. (2020), "Reliability analysis of subsea blowout preventers with condition-based maintenance using stochastic Petri nets", *Journal of Loss Prevention in the Process Industries*, Vol. 63104026.
- Lee, J. & Mitici, M. (2020), "An integrated assessment of safety and efficiency of aircraft maintenance strategies using agent-based modelling and stochastic Petri nets", *Reliability Engineering & System Safety*, Vol. 202107052.
- Pestov, I. (2009), "Dynamic network analysis for understanding complex systems and processes", *Defence Research and Development Canada*,.
- S., B., A., S. & L., K. (2015), "Main factors to select a cruise homeport in the Mediterranean region: A perspective from the cruise industry agents", in *2015 International Conference on Logistics, Informatics and Service Sciences (LISS)*, pp. 1-5.
- Wold, S., Esbensen, K. & Geladi, P. (1987), "Principal component analysis", *Chemometrics and Intelligent Laboratory Systems*, Vol. 2 No. 1, pp. 37-52.



ICM Corporation

--The Value Creation of Port Logistics Big Data

Dear Port Users:

I would like to thank you for your trust in choosing ICM Corporation as your partner. ICM Corporation insists on being customer-oriented and adheres to the concept of “people-oriented and win-win cooperation”. Bringing tremendous success to our customers is a constant motivation for us at ICM Corporation. ICM Corporation has implemented the new logistics core strategy of “Supply Chain + Big Data + AIOT” and created a data and analytics (D&A) system with independent intellectual property rights. ICM Corporation conducted a four-day D&A system maturity assessment and optimization exercise on 2022.2.18.

➤ Overview of Targets

- Maximizing the value of ICM Corporation’s data assets.
- Measuring the maturity capability of ICM Corporation’s D&A system through people, technologies and processes.
- Optimizing the D&A system architecture to improve system analysis.

➤ Solutions

The consulting team develops a standard D&A system meta-network model based on the port logistics industry’s most advanced D&A system architecture. The model effectively realizes the visual integration of people, relevant technologies, mature processes and data information. Through meta-network analysis, 12 practically meaningful indicators were selected to construct the D&A system maturity assessment system. Feeding the current status of ICM’s D&A system into a standard D&A system meta-network enables the assessment of the maturity of ICM’s D&A system.

Based on ICM’s D&A system, the consultancy team constructed a stochastic Petri network model (SPN) for port logistics. The SPN model enables the simulation of logistic transport detention times based on ICM’s D&A system data. Finally, ICM’s D&A system optimization is implemented based on the standard D&A system meta-network model.

➤ Results Analysis

- ICM's D&A system maturity assessment level is **Excellent**.
- The average dwell time of port transport equipment decreased by **38.7%**.

ICM’s D&A systems consultancy project has shown that the modelling tools provided by the consultancy are a powerful tool for assessing and planning logistics business processes. ICM Corporation will continue to work with this consultancy to continuously improve the data asset application capabilities of the D&A system. ICM Corporation will strive to develop into a preeminent port logistics service provider, offering our customers complete logistics solutions and logistics services. We hope you will keep your faith in ICM’s D&A system and ICM Corporation!

Yours sincerely,
ICM Corporation

